

METRIC NUT & FERRULE

NUT DIN 3870, FERRULE DIN 3861

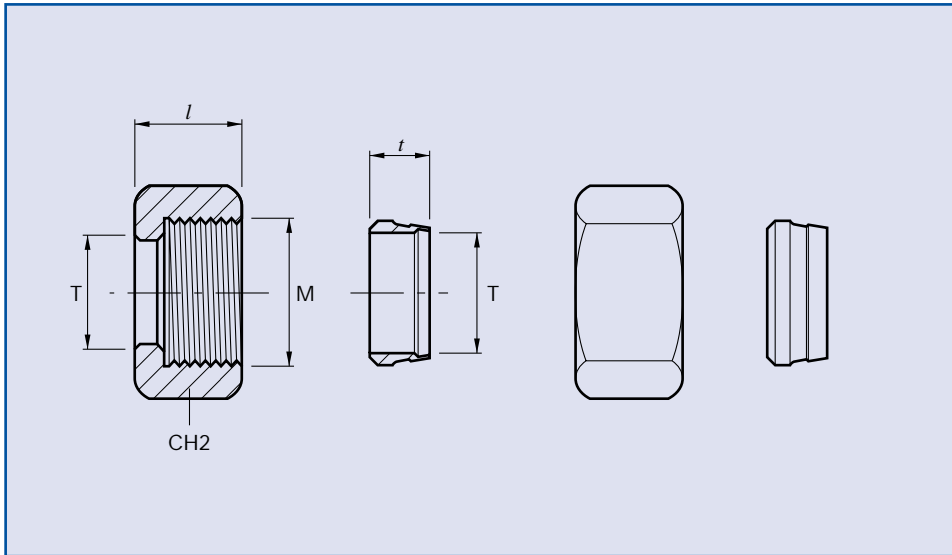

Series	ØT	Nut Part N°	ØM	CH2	l	Ferrule Part N°	t
L	6	MN6L	M12 x 1.5	14	14.5	MF6	9.5
L	8	MN8L	M14 x 1.5	17	14.5	MF8	9.5
L	10	MN10L	M16 x 1.5	19	15.5	MF10	10
L	12	MN12L	M18 x 1.5	22	15.5	MF12	10
L	15	MN15L	M22 x 1.5	27	17	MF15L	10
L	18	MN18L	M26 x 1.5	32	18	MF18L	10
L	22	MN22L	M30 x 2	36	20	MF22L	10.5
L	28	MN28L	M36 x 2	41	21	MF28L	10.5
L	35	MN35L	M45 x 2	50	24	MF35L	13
L	42	MN42L	M52 x 2	60	24	MF42L	13.5
S	6	MN6	M14 x 1.5	17	16.5	MF6	9.5
S	8	MN8	M16 x 1.5	19	16.5	MF8	9.5
S	10	MN10	M18 x 1.5	22	17.5	MF10	10
S	12	MN12	M20 x 1.5	24	17.5	MF12	10
S	14	MN14	M22 x 1.5	27	20.5	MF14	10
S	16	MN16	M24 x 1.5	30	20.5	MF16	10.5
S	20	MN20	M30 x 2	36	24	MF20	12.5
S	25	MN25	M36 x 2	46	27	MF25	12.5
S	30	MN30	M42 x 2	50	29	MF30	13
S	38	MN38	M52 x 2	60	32.5	MF38	13.5

Part numbers indicated are for **Carbon Steel Couplings** only.

For **316 Stainless Steel Couplings**, add suffix **SS** to part number.