

IMPERIAL BSP PARALLEL MALE STUD COUPLINGS

FOR O.D. TUBES

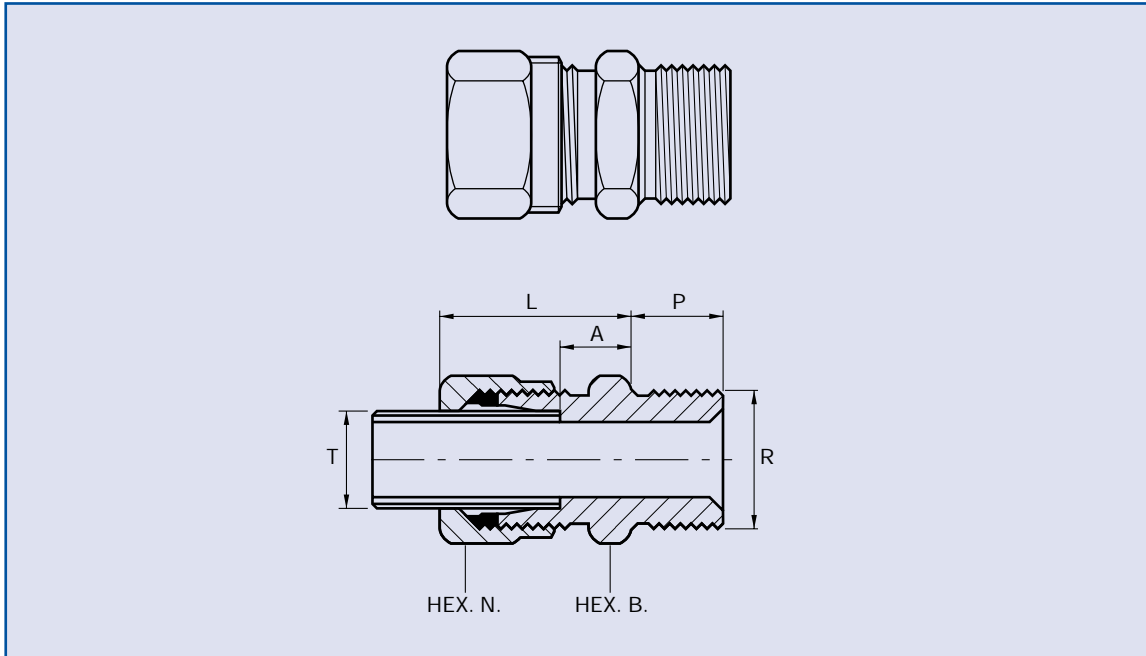

Part No.	Tube Dia. T.	BSP Thread R.	Nut Hexagon N.	Body Hexagon B.	Tube Abutment A.	Thread Length P.	O/A Length L.
MC4-2	1/4"	1/8"	.710"	.625"	9/32"	3/8"	3 1/32"
MC4-4	1/4"	1/4"	.710"	.710"	9/32"	7/16"	3 1/32"
MC4-6	1/4"	3/8"	.710"	.920"	11 1/32"	1/2"	1 1/32"
MC5-4	5/16"	1/4"	.710"	.710"	5/16"	7/16"	1"
MC6-4	3/8"	1/4"	.820"	.710"	5/16"	7/16"	1 1/32"
MC6-6	3/8"	3/8"	.820"	.920"	3/8"	1/2"	1 3/32"
MC6-8	3/8"	1/2"	.820"	1.10"	7/16"	5/8"	1 5/32"
MC8-4	1/2"	1/4"	.920"	.820"	11 1/32"	7/16"	1 3/32"
MC8-6	1/2"	3/8"	.920"	.920"	13 1/32"	1/2"	1 5/32"
MC8-8	1/2"	1/2"	.920"	1.10"	15 1/32"	5/8"	1 7/32"
MC8-12	1/2"	3/4"	.920"	1.30"	19 1/32"	3/4"	1 11/32"
MC10-8	5/8"	1/2"	1.10"	1.10"	7/16"	5/8"	1 7/32"
MC10-12	5/8"	3/4"	1.10"	1.30"	9/16"	3/4"	1 11/32"
MC12-8	3/4"	1/2"	1.20"	1.10"	7/16"	5/8"	1 1/4"
MC12-12	3/4"	3/4"	1.20"	1.30"	9/16"	3/4"	1 3/8"
MC14-12	7/8"	3/4"	1.375"	1.30"	1/2"	3/4"	1 3/8"
MC14-16	7/8"	1"	1.375"	1.67"	5/8"	7/8"	1 1/2"
MC16-12	1"	3/4"	1.67"	1.48"	19 1/32"	3/4"	1 17/32"
MC16-16	1"	1"	1.67"	1.67"	21 1/32"	7/8"	1 19/32"
MC16-20	1"	1 1/4"	1.67"	2.05"	23 1/32"	1"	1 21/32"
MC20-16	1 1/4"	1"	2.05"	1.67"	3/4"	7/8"	1 23/32"
MC20-20	1 1/4"	1 1/4"	2.05"	2.05"	13 1/16"	1"	1 25/32"
MC20-24	1 1/4"	1 1/2"	2.05"	2.22"	7/8"	1"	1 27/32"
MC24-20	1 1/2"	1 1/4"	2.22"	2.05"	13 1/16"	1"	1 1/8"
MC24-24	1 1/2"	1 1/2"	2.22"	2.22"	7/8"	1"	1 15/16"

NOTE: THE BSP THREADS ARE ALL COUNTERSUNK 60°, SUITABLE FOR HOSE CONNECTION.

Part numbers indicated are for **Carbon Steel Couplings** only.
For **316 Stainless Steel Couplings**, add suffix **SS** to part number.