

METRIC MALE STUD COUPLINGS – WD

THREAD: BSP CYLINDRICAL (UNI ISO 228)
WD CAPTIVE SEAL – PERBUNAN OR VITON

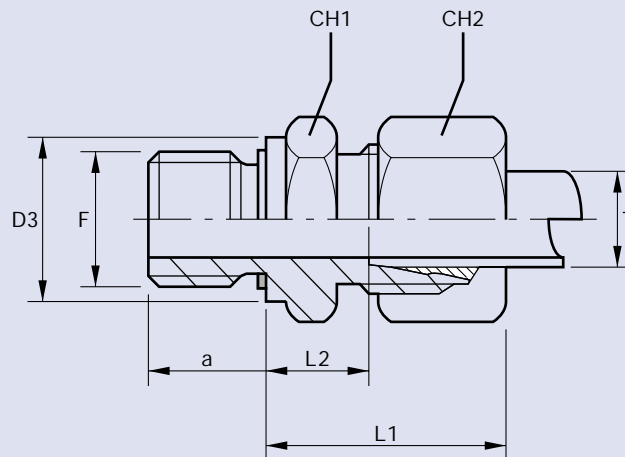

Series	NP	ØT	Part N°	F	L1	L2	a	CH1	CH2	D3
L	315	6	MMC6-2LWD	1/8"	23	8.5	8	14	14	14
L	315	8	MMC8-4LWD	1/4"	25	10	12	19	17	19
L	315	10	MMC10-4LWD	1/4"	26	11	12	19	19	19
L	315	12	MMC12-6LWD	3/8"	27	12.5	12	22	22	22
L	315	15	MMC15-8LWD	1/2"	29	14	14	27	27	27
L	160	18	MMC18-8LWD	1/2"	31	14.5	14	27	32	27
L	160	22	MMC22-12LWD	3/4"	33	16.5	16	32	36	32
L	160	28	MMC28-16LWD	1"	34	17.5	18	41	41	40
L	160	35	MMC35-20LWD	1 1/4"	39	17.5	20	50	50	50
L	160	42	MMC42-24LWD	1 1/2"	42	19	22	55	60	55
S	630	6	MMC6-4WD	1/4"	28	13	12	19	17	19
S	630	8	MMC8-4WD	1/4"	30	15	12	19	19	19
S	630	10	MMC10-6WD	3/8"	31	15	12	22	22	22
S	630	12	MMC12-6WD	3/8"	33	17	12	22	24	22
S	630	14	MMC14-8WD	1/2"	37	19	14	27	27	27
S	630	16	MMC16-8WD	1/2"	37	18.5	14	27	30	27
S	630	20	MMC20-12WD	3/4"	42	20.5	16	32	36	32
S	630	25	MMC25-16WD	1"	47	23	18	41	46	40
S	630	30	MMC30-20WD	1 1/4"	50	23.5	20	50	50	50
S	315	38	MMC38-24WD	1 1/2"	57	26	22	55	60	55

Perbunan captive seal temperature range -20°C to +90°C. (Viton captive seal temperature range -20°C to +200°C on request).

Part numbers indicated are for **Carbon Steel Couplings** only.

For **316 Stainless Steel Couplings**, add suffix **SS** to part number.