

METRIC BSP TAPER MALE STUD COUPLINGS

THREAD: BSP TAPERED (DIN 3858)

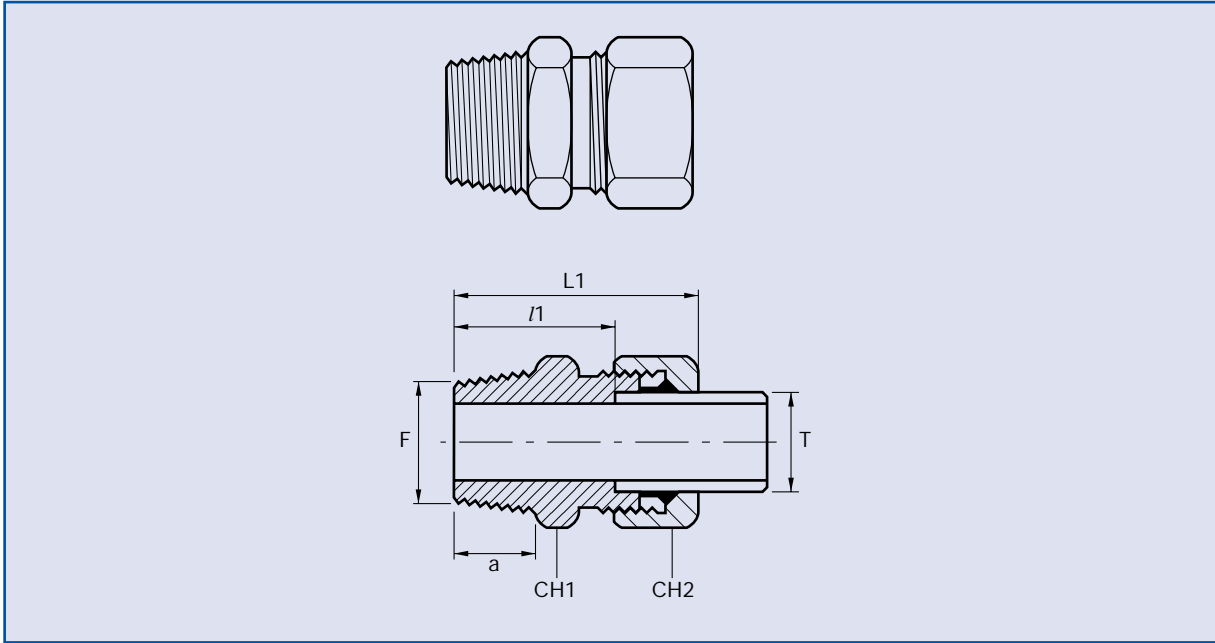

Series	NP	ØT	Part N°	ØF	CH1	CH2	a	L1	l1
L	315	6	MMC6-2TL	1/8"	12	14	10	32	17
L	315	6	MMC6-4TL	1/4"	17	14	13	36	21
L	315	8	MMC8-4TL	1/4"	17	17	13	36	21
L	315	8	MMC8-6TL	3/8"	19	17	13	37	22
L	315	10	MMC10-4TL	1/4"	17	19	13	37	22
L	315	10	MMC10-6TL	3/8"	19	19	13	38	23
L	315	12	MMC12-6TL	3/8"	19	22	13	38	23
L	315	12	MMC12-4TL	1/4"	19	22	13	38	23
L	315	12	MMC12-8TL	1/2"	24	22	16	41	26
L	315	15	MMC15-8TL	1/2"	24	27	16	42	27
L	315	15	MMC15-6TL	3/8"	24	27	13	39	24
L	315	18	MMC18-8TL	1/2"	27	32	16	44	27.5
L	160	22	MMC22-12TL	3/4"	32	36	18	48	31.5
L	160	28	MMC28-16TL	1"	41	41	20	51	34.5
L	160	35	MMC35-20TL	1 1/4"	46	50	21	58	36.5
L	160	42	MMC42-24TL	1 1/2"	55	60	22	61	38
S	630	6	MMC6-4T	1/4"	17	17	13	41	26
S	630	8	MMC8-4T	1/4"	17	19	13	41	26
S	630	10	MMC10-6T	3/8"	19	22	13	42	25.5
S	630	12	MMC12-6T	3/8"	22	24	13	44	27.5
S	630	12	MMC12-8T	1/2"	24	24	16	47.5	30.5
S	630	14	MMC14-8T	1/2"	24	27	16	50	32
S	400	16	MMC16-8T	1/2"	27	30	16	50	31.5
S	400	20	MMC20-12T	3/4"	32	36	18	57	35.5
S	400	25	MMC25-16T	1"	41	46	20	64	40
S	250	30	MMC30-20T	1 1/4"	46	50	21	68	41.5
S	250	38	MMC38-24T	1 1/2"	55	60	22	76	45

Part numbers indicated are for **Carbon Steel Couplings** only.

For **316 Stainless Steel Couplings**, add suffix **SS** to part number.