

METRIC REDUCING COUPLINGS

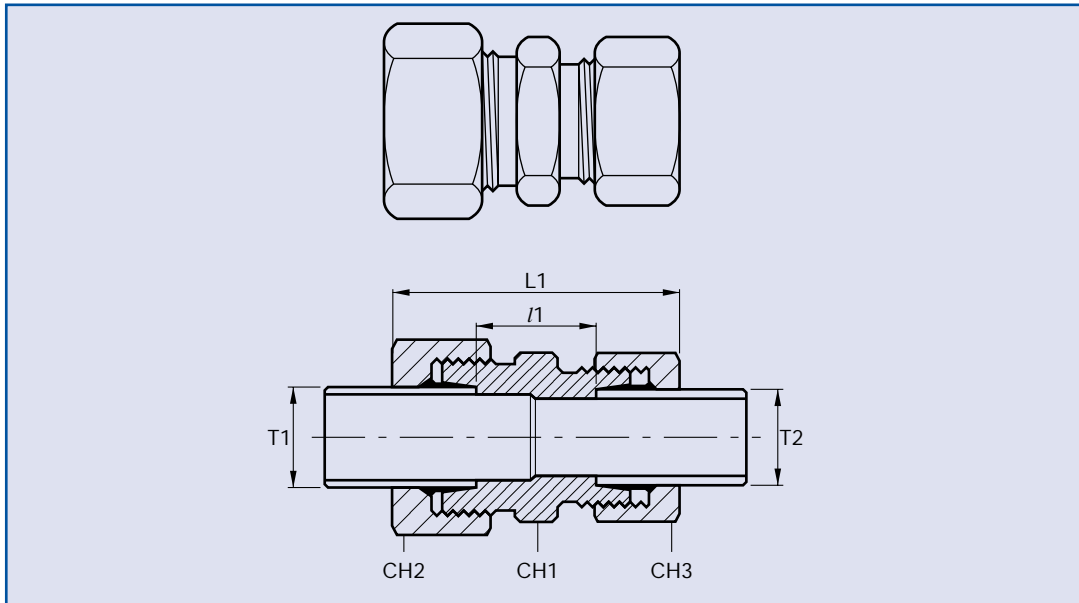

Series	NP	ØT	Part N°	CH1	CH2	CH3	L1	l1
L	315	8-06	MRC8-6L	14	17	14	41	11
L	315	10-06	MRC10-6L	17	19	14	42	12
L	315	10-08	MRC10-8L	17	19	17	42	12
L	315	12-08	MRC12-8L	19	22	17	42	13
L	315	12-10	MRC12-10L	19	22	19	44	14
L	315	15-10	MRC15-10L	24	27	19	45	15
L	315	15-12	MRC15-12L	24	27	22	45	15
L	315	18-12	MRC18-12L	27	32	22	47	15.5
L	315	18-15	MRC18-15L	27	32	27	48	16.5
L	160	22-15	MRC22-15L	32	36	27	50	18.5
L	160	22-18	MRC22-18L	32	36	32	51	18
L	160	28-18	MRC28-18L	41	41	32	52	19
L	160	28-22	MRC28-22L	41	41	36	54	21
L	160	35-22	MRC35-22L	46	50	36	59	21
L	160	35-28	MRC35-28L	46	50	41	59	21
L	160	42-28	MRC42-28L	55	60	41	62	22.5
L	160	42-35	MRC42-35L	55	60	50	66	21.5
S	630	8-06	MRC8-6	17	19	17	48	18
S	630	10-06	MRC10-6	19	22	17	49	17.5
S	630	10-08	MRC10-8	19	22	19	49	17.5
S	630	12-08	MRC12-8	22	24	19	51	19.5
S	630	12-10	MRC12-10	22	24	22	52	19
S	630	14-10	MRC14-10	24	27	22	55	20.5
S	630	14-12	MRC14-12	24	27	24	55	20.5
S	400	16-12	MRC16-12	27	30	24	55	20
S	400	16-14	MRC16-14	27	30	27	58	21.5
S	400	20-14	MRC20-14	32	36	27	63	23.5
S	400	20-16	MRC20-16	32	36	30	63	23
S	400	25-16	MRC25-16	41	46	30	68	25.5
S	400	25-20	MRC25-20	41	46	36	71	25.5
S	400	30-20	MRC30-20	46	50	36	74	26
S	400	30-25	MRC30-25	46	50	46	77	26.5
S	315	38-25	MRC38-25	55	60	46	84	29
S	315	38-30	MRC38-30	55	60	50	87	29.5

Part numbers indicated are for **Carbon Steel Couplings** only.

For **316 Stainless Steel Couplings**, add suffix **SS** to part number.